

| ECO NO. | DATE | REV. | INITIAL RELEASE | REVISION RECORD | AUTH. | DR. BY |
|---------|------------|------|--|-----------------|-------|--------|
| 7723 | 02/13/2024 | A | CHANGE LAM/CRANK SPLICE TO J1-9 (1-5VDC) | | | EF |
| 7731 | 02/13/2024 | B | ADDED NOTE ON RELAY CONNECTIONS 87 & 87B | | | EF |

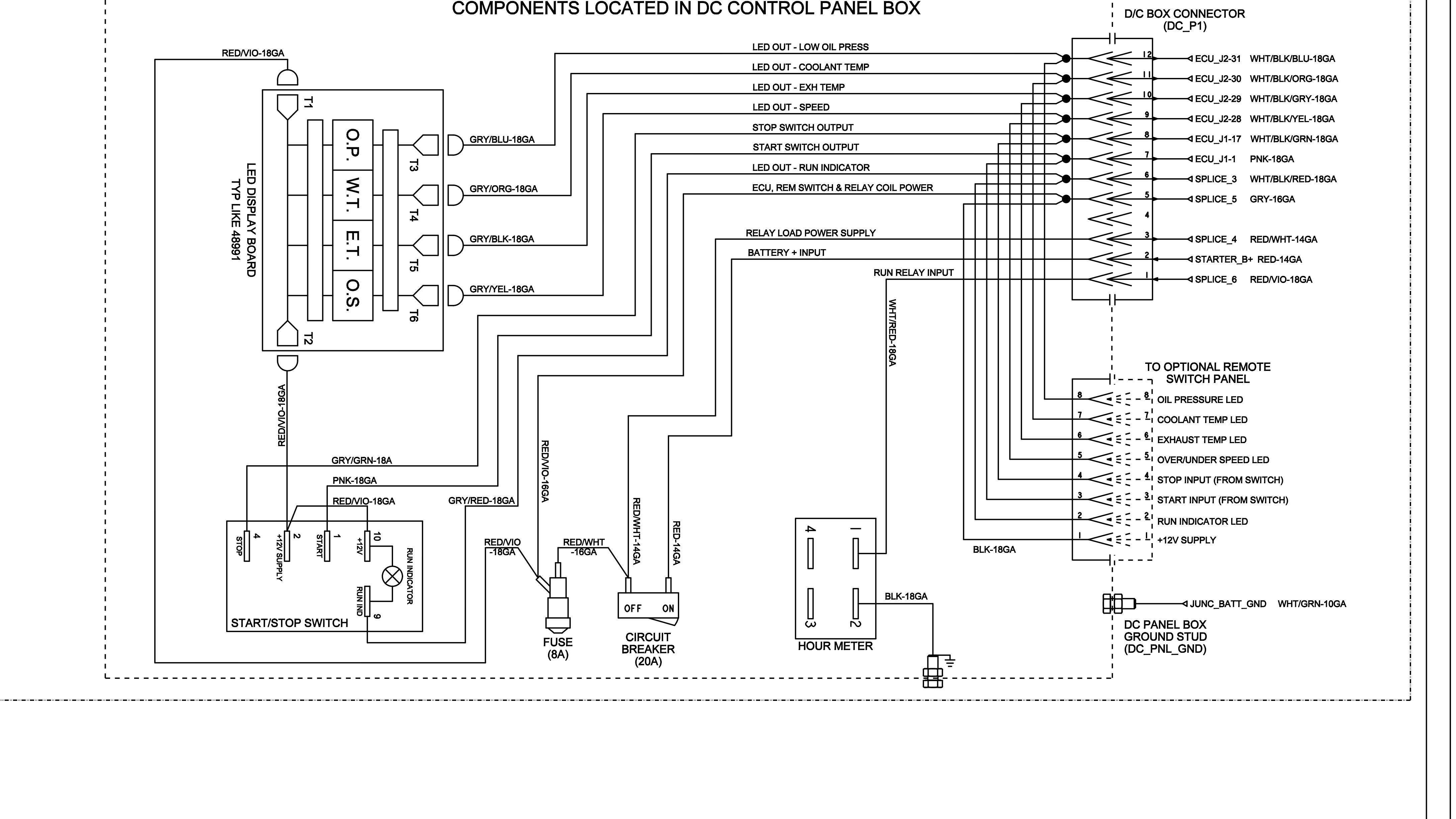
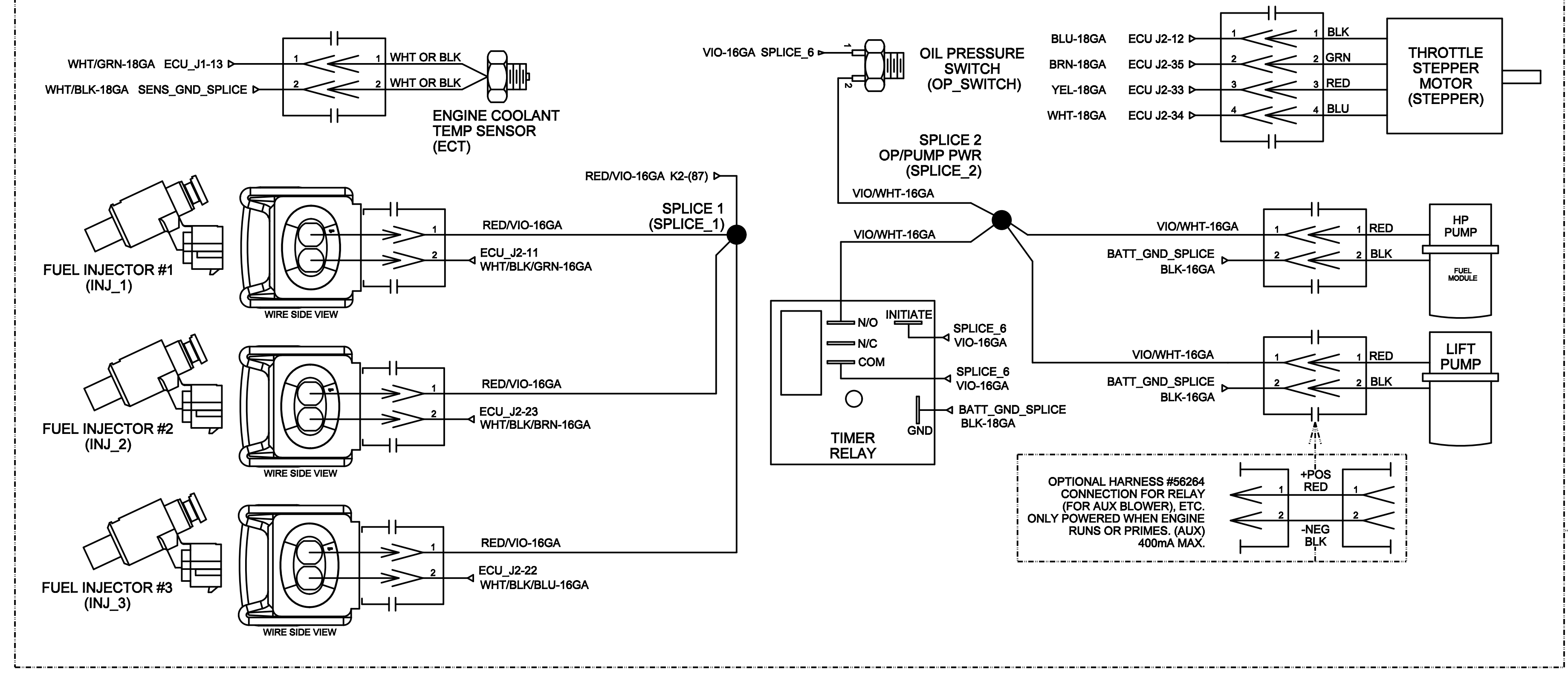
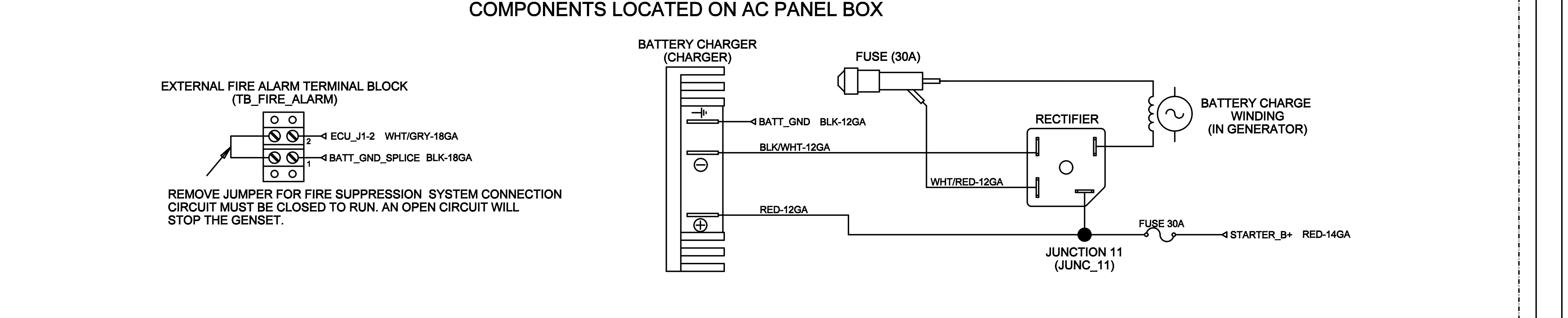
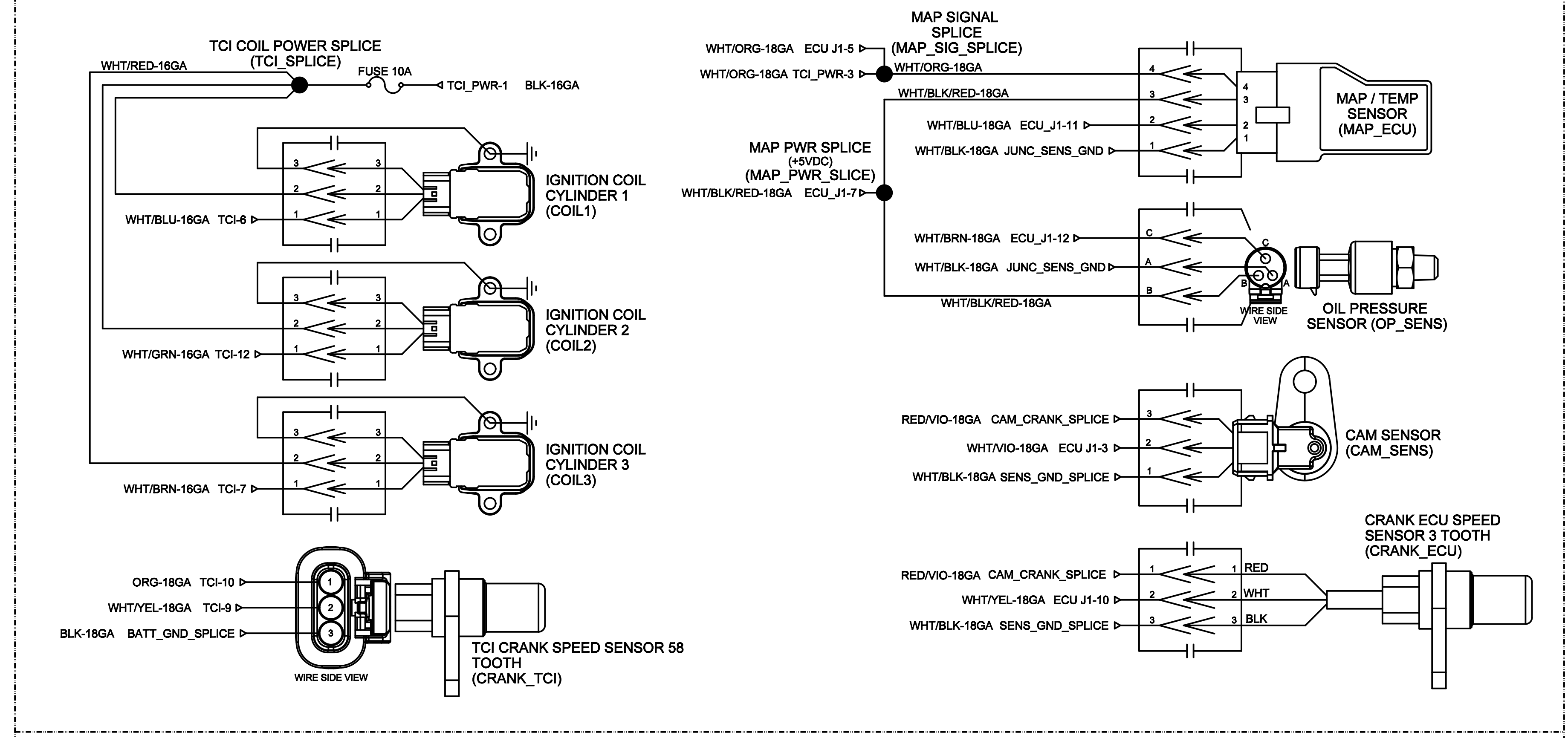
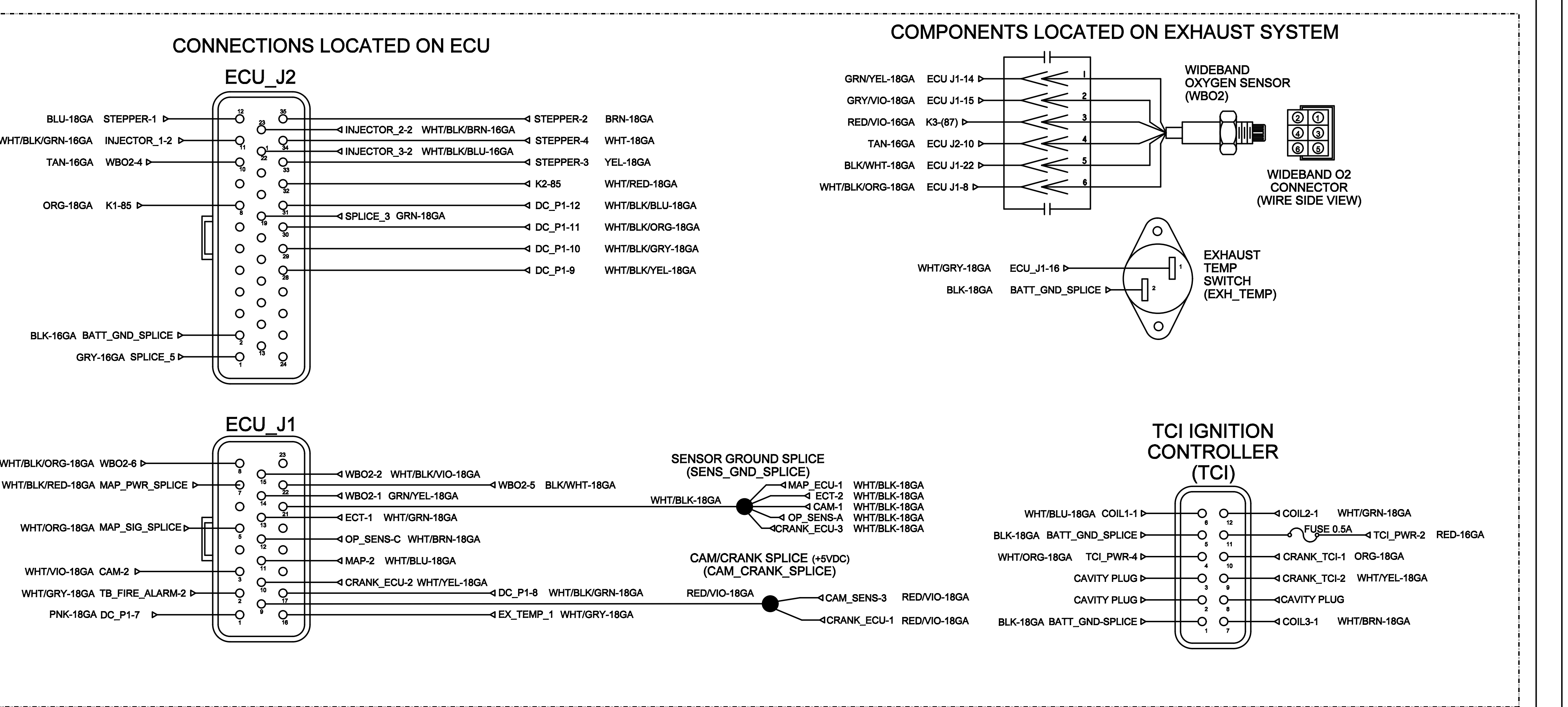
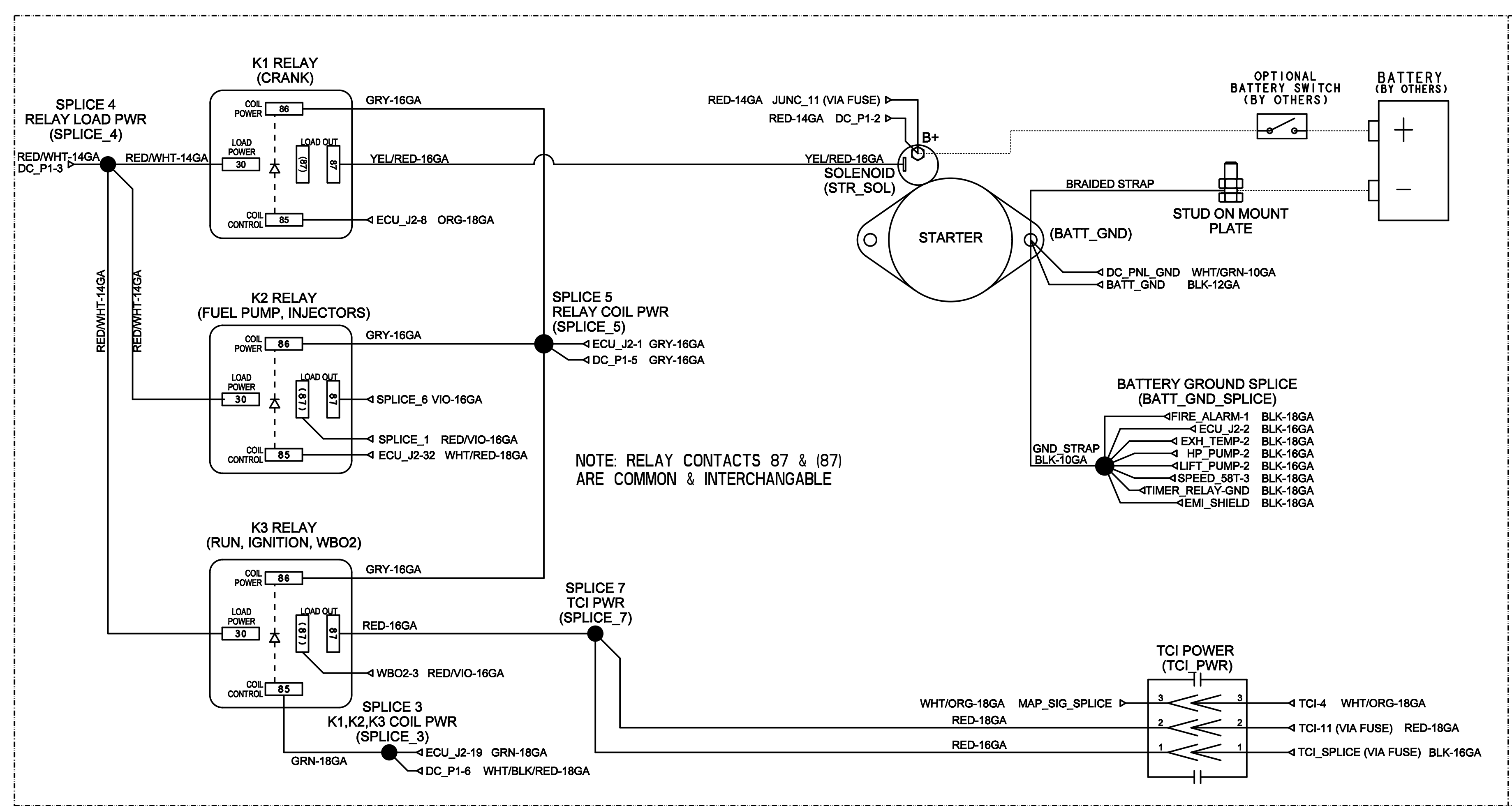

| | | | |
|--|-------------------|------------------------------------|--------------------------|
| TOLERANCES DIMENSIONS UNLESS OTHERWISE SPECIFIED | | WESTERBEKE Engine & Generator | |
| INCHES: .0005 | MILLIMETERS: .025 | TITLE: DIGGENSET WIRE 5.0-7.5 MCGB | DATE CREATED: 02/13/2024 |
| FRAMES: .001 | HOLES: .001 | DRAWN BY: EF | DATE: 02/13/2024 |
| APPROVED BY: EF | DATE: 02/13/2024 | SCALE: N/A | SIZE: 11x17 |
| THIRD ANGLE PROJECTION | | SCALE: N/A | DRAWING NUMBER: 58266 |
| THIS DRAWING IS PROPRIETARY TO WESTERBEKE CORP. AND MAY NOT BE REPRODUCED OR TRANSMITTED IN ANY FORM OR BY ANY MEANS WITHOUT EXPRESS WRITTEN PERMISSION. | | REV: 1 OF 1 | REV: B |